

4

3

2

1

B

B

A

A

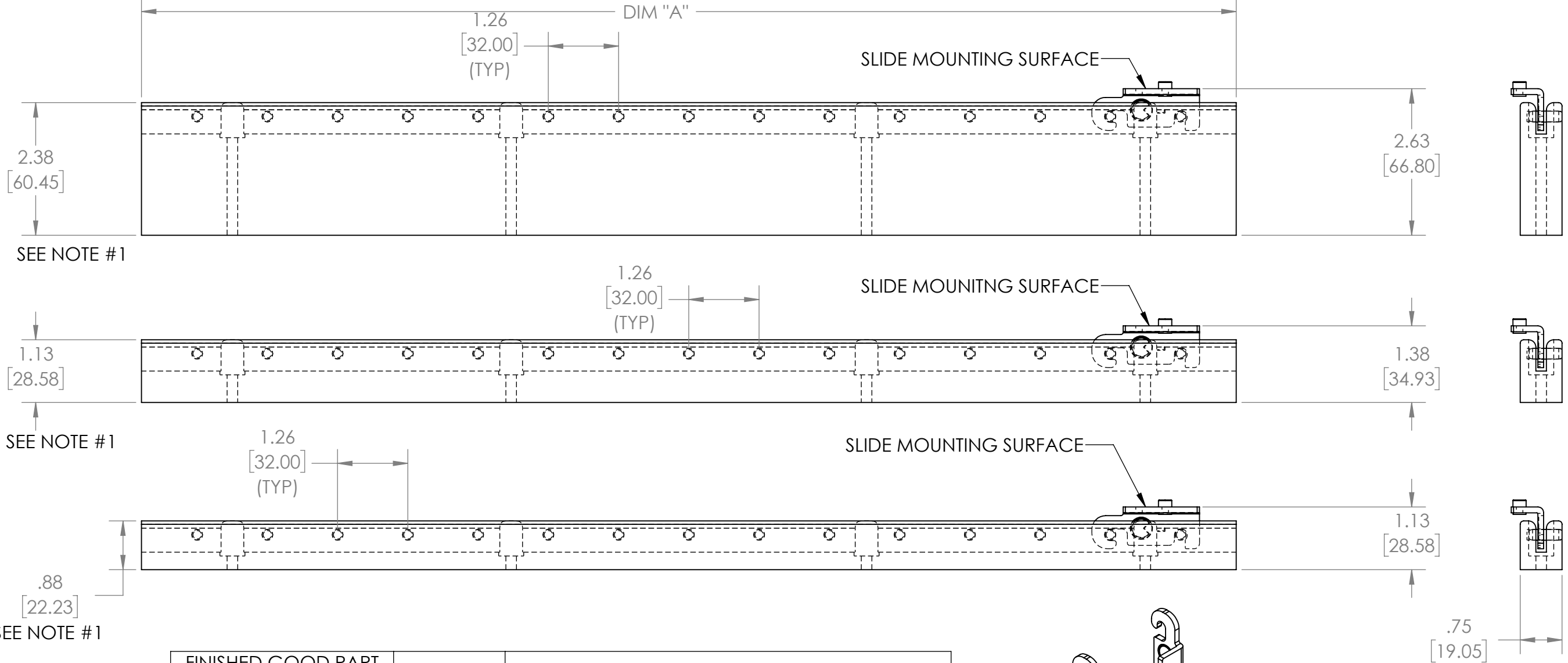

SEE NOTE #1

SEE NOTE #1

SEE NOTE #1

FINISHED GOOD PART NUMBER	DIM "A"	SHORT DESCRIPTION
4PIL-20-088-1	19.64	19.64 X .88 PILASTER SYSTEM - 2 HDW SET
4PIL-27-088-1	27.20	27.2 X .88 PILASTER SYSTEM - 3 HDW SET
4PIL-20-113-1	19.64	19.64 X 1.13 PILASTER SYSTEM - 2 HDW SET
4PIL-27-113-1	27.20	27.2 X 1.13 PILASTER SYSTEM - 3 HDW SET
4PIL-20-238-1	19.64	19.64 X 2.38 PILASTER SYSTEM - 2 HDW SET
4PIL-27-238-1	27.20	27.2 X 2.38 PILASTER SYSTEM - 3 HDW SET

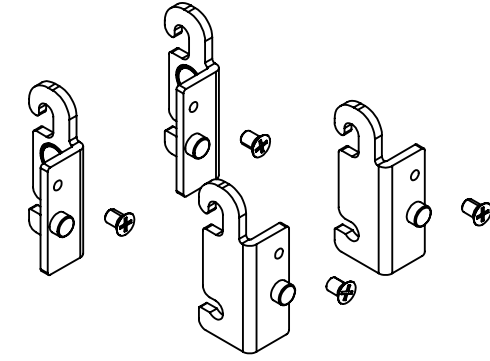

1 HDW SET (1 DRAWER)

NOTE:
 1) THESE STANDARDS, THE 2.38 & 1.13 WIDTH CAN BE TRIMMED TO FIT YOUR CUSTOM SIZE OPENING OR DRAWERS. THE MINIMUM WIDTH THAT THESE CAN BE CUT DOWN TO IS .88 DIMENSION, NO LESS.

CUSTOMER DRAWING



PROPRIETARY AND CONFIDENTIAL
 This drawing is the property of Rev-A-Shelf LLC (RAS) and is disclosed in confidence to the extent its subject matter is original to RAS. Any vendor receiving this drawing from RAS shall hold and use this drawing for the sole benefit of RAS and shall not disclose it to, or use or reproduce it for any third party, or perform any act adverse to the interest of RAS with respect to this drawing without the express written permission of RAS. Vendors shall not revise any physical, dimensional or performance characteristic unless authorized by Rev-A-Shelf Engineering.

UNCONTROLLED IF PRINTED

REV	DATE	BY	DESCRIPTION OF CHANGE

UNLESS OTHERWISE SPECIFIED: TOLERANCES = INCH/(MM) MAT. DEC. (WOOD) .XX +/- .03 [.8mm] (OTHER) .XX +/- .02 [.5mm] (ALL) .XXX +/- .005 [.13 mm] FRACTIONS +/- 1/32 [.8 mm] ANGLES +/- 1/2°		Description: WOOD PILASTER STANDARD AND SLIDE MOUNTING HARDWARE	
First Angle Projection		PART NO. SEE CHART ABOVE	
MATERIAL	FINISH	SIZE B	DWG. NO. 4PIL-XX-XXX-1_REVA
DO NOT SCALE DRAWING	NAME	DATE	REV
DRAWN	BKT	1/30/24	SCALE: 1:8 WEIGHT: SHEET 1 OF 2

4

3

2

1

4

3

2

1

PART DIMENSIONS	
WIDTH	□
DEPTH	□
HEIGHT	□

MIN CABINET OPENING				
	FACE FRAME	FRAMELESS	INSET FACE FRAME	INSET FRAMELESS
WIDTH	□	□	□	□
DEPTH	□	□	□	□
HEIGHT *	□	□	□	□

* MCO HEIGHT DEPENDENT ON BIN PLACEMENT AND UTENSILS USED

SLIDE SPECIFICATIONS				
SLIDE MANUFACTURER				
SLIDE PART NO.		RELEASE PART NO.		
SLIDE TYPE		SLIDE EXTENSION		MAX WEIGHT RATING
SLIDE CLOSING		SLIDE LENGTH	□	
SLIDE MOUNTING		SLIDE FINISH	ZINC	

CUSTOMER DRAWING



PROPRIETARY AND CONFIDENTIAL
 This drawing is the property of Rev-A-Shelf LLC (RAS) and is disclosed in confidence to the extent its subject matter is original to RAS. Any vendor receiving this drawing from RAS shall hold and use this drawing for the sole benefit of RAS and shall not disclose it to, or use or reproduce it for any third party, or perform any act adverse to the interest of RAS with respect to this drawing without the express written permission of RAS. Vendors shall not revise any physical, dimensional or performance characteristic unless authorized by Rev-A-Shelf Engineering.

UNCONTROLLED IF PRINTED

UNLESS OTHERWISE SPECIFIED:		Description:	
TOLERANCES = INCH/(MM) MAT. DEC. (WOOD) .XX +/- .03 [.8mm] (OTHER) .XX +/- .02 [.5mm] (ALL) .XXX +/- .005 [.13 mm] FRACTIONS +/- 1/32 [.8 mm] ANGLES +/- 1/2°		PART NO.	
First Angle Projection		SIZE B	DWG. NO. 4PIL-XX-XXX-1_REVA
MATERIAL	FINISH	SCALE: 1:6	WEIGHT:
DO NOT SCALE DRAWING	NAME	DATE	SHEET 2 OF 2
REV	DATE	BY	DESCRIPTION OF CHANGE
			DRAWN

4

3

2

1

B

B

A

A